

 **TADANO FAUN**

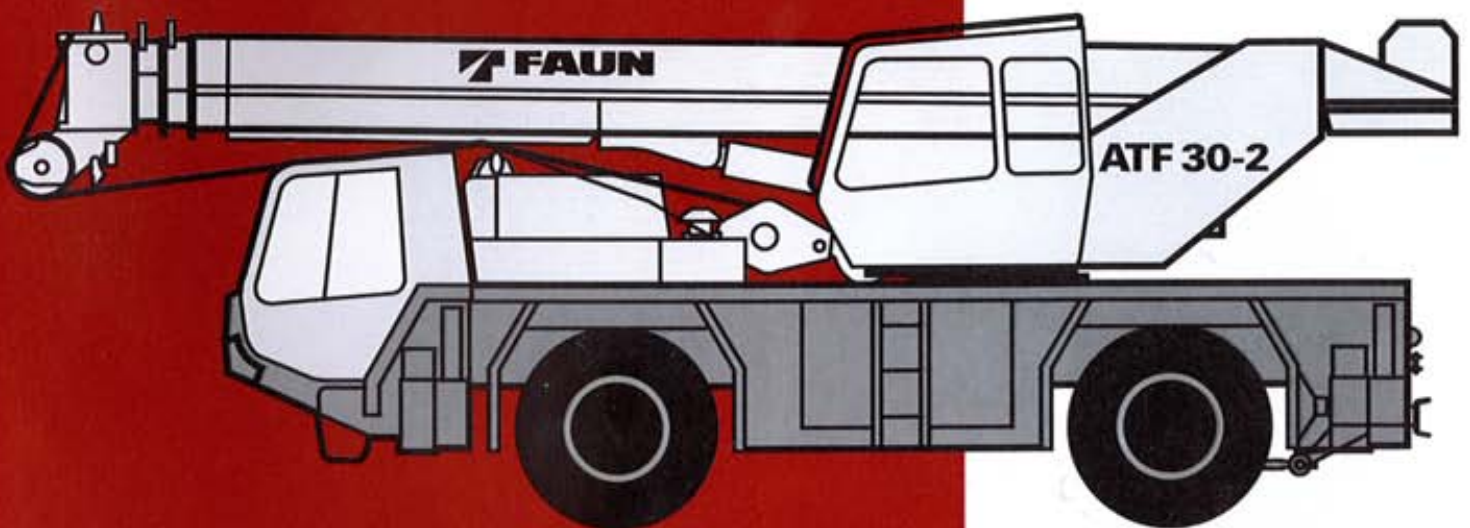

# ATF 30-2



Maße / Dimensions / Dimensions (mm)  
 Gewichte / Weights / Poids  
 Geschwindigkeiten / Speeds / Vitesses

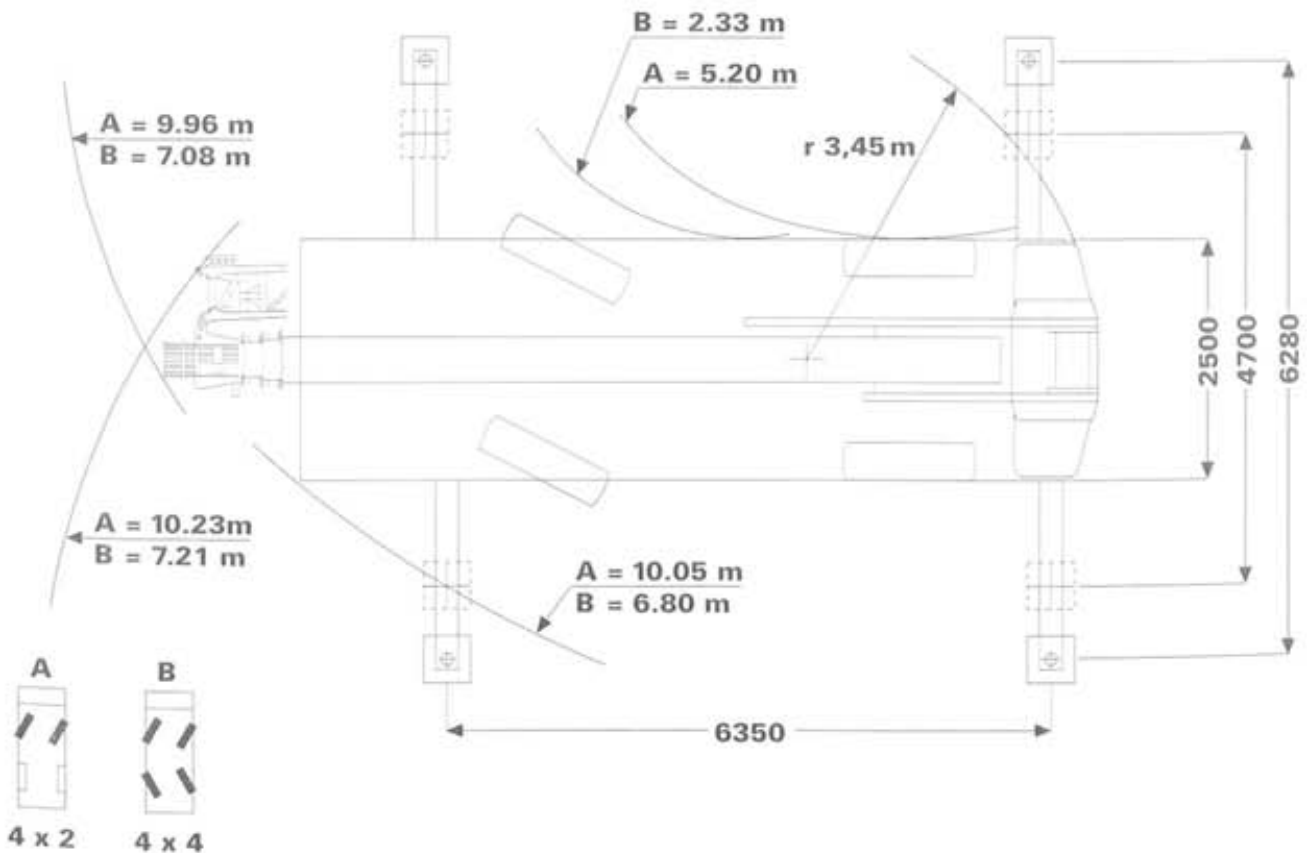
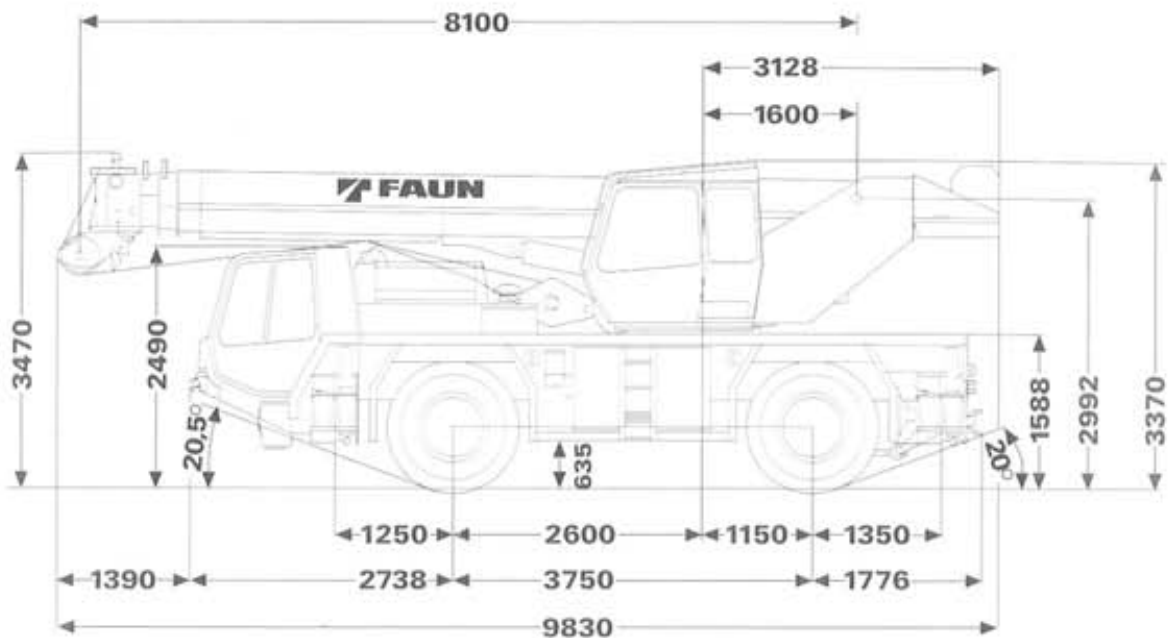

Standardausführung  
Standard Version  
Version Standard

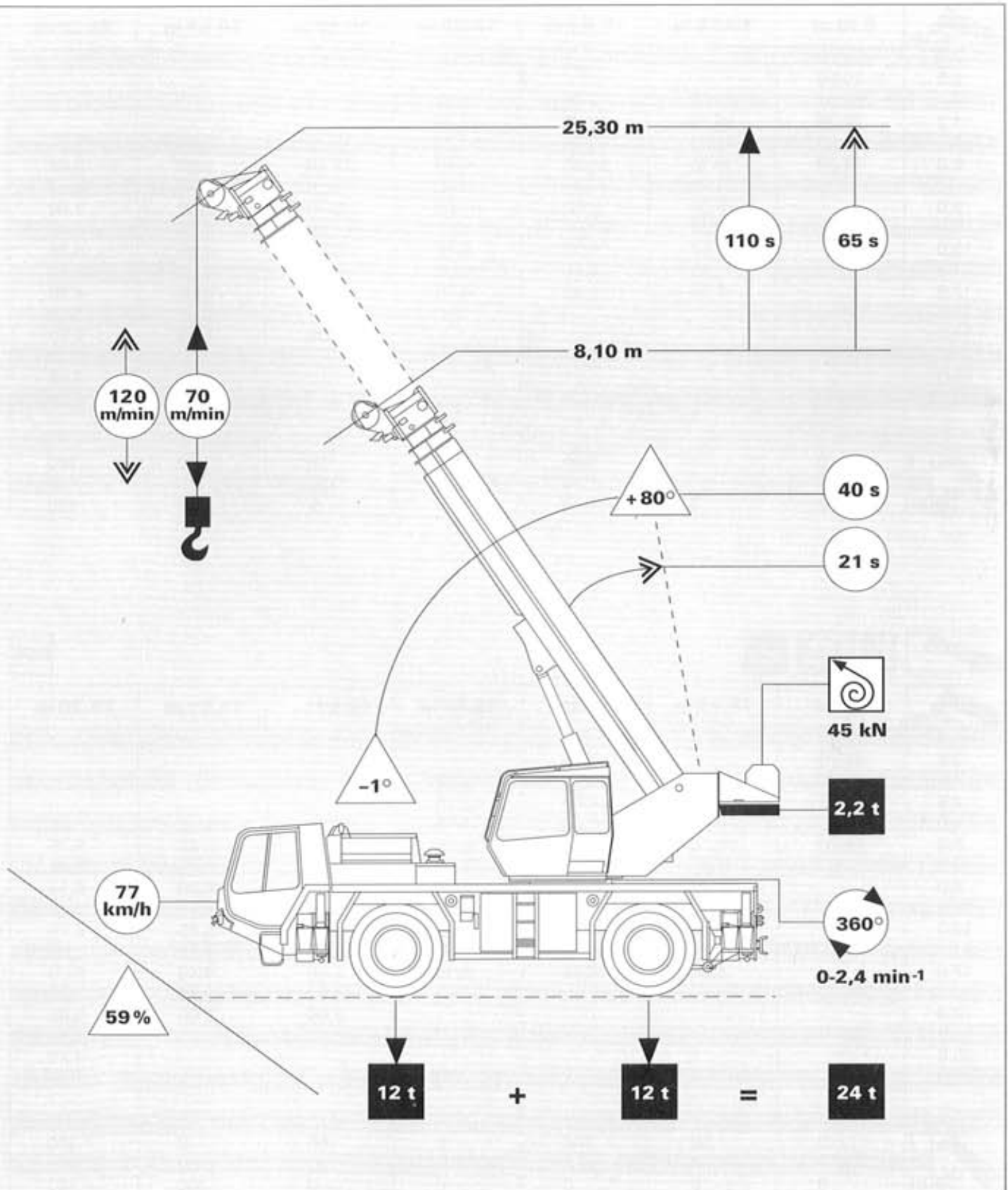

Tragfähigkeiten am Teleskopausleger  
 Lifting capacities on telescopic boom  
 Capacités de levage à la flèche telescopique

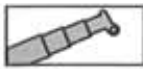

2,2t

DIN

→ m	8.10 m	13.83 m	13.83 m	13.83 m	19.57 m	19.57 m	25.30 m
3.0	30.00						
3.5	26.00						
4.0	22.60	18.00	13.00	12.90			
4.5	20.00	16.70	13.00	11.80			
5.0	17.80	15.30	13.00	11.10	12.70	8.60	
6.0	14.60	13.10	11.80	9.60	11.40	7.60	9.00
7.0		11.30	10.40	8.50	10.10	6.70	8.25
8.0		9.00	8.60	7.60	8.80	6.00	7.50
9.0		7.30	7.00	6.90	7.10	5.30	6.85
10.0		6.10	5.70	6.30	6.00	4.80	6.20
11.0		5.10	4.80	5.50	5.00	4.30	5.40
12.0		4.30	4.00	4.70	4.20	4.00	4.60
14.0					3.15	3.40	3.50
16.0					2.35	2.80	2.70
18.0							2.10
20.0							1.65
22.0							1.25
I	0	50	100	0	100	0	100
II	0	50	0	100	100	100	100
III	0	0	0	0	0	100	100



2,2t

85%

→ m	8.10 m	13.83 m	13.83 m	13.83 m	19.57 m	19.57 m	25.30 m
3.0	32.00						
3.5	27.80						
4.0	24.20	19.35	14.00	13.90			
4.5	21.40	17.90	14.00	12.70			
5.0	19.05	16.45	14.00	11.95	13.70	9.30	
6.0	15.70	14.10	12.75	10.35	12.30	8.20	9.75
7.0		12.20	11.25	9.20	10.95	7.25	8.95
8.0		9.75	9.35	8.25	9.55	6.50	8.15
9.0		7.95	7.65	7.50	7.75	5.75	7.45
10.0		6.65	6.25	6.85	6.55	5.25	6.75
11.0		5.60	5.30	6.00	5.50	4.70	5.90
12.0		4.80	4.45	5.15	4.65	4.40	5.05
14.0					3.45	3.75	3.85
16.0					2.55	3.05	3.00
18.0							2.35
20.0							1.85
22.0							1.50
I	0	50	100	0	100	0	100
II	0	50	0	100	100	100	100
III	0	0	0	0	0	100	100

Hubhöhen  
Lifting heights  
Hauteurs de levage





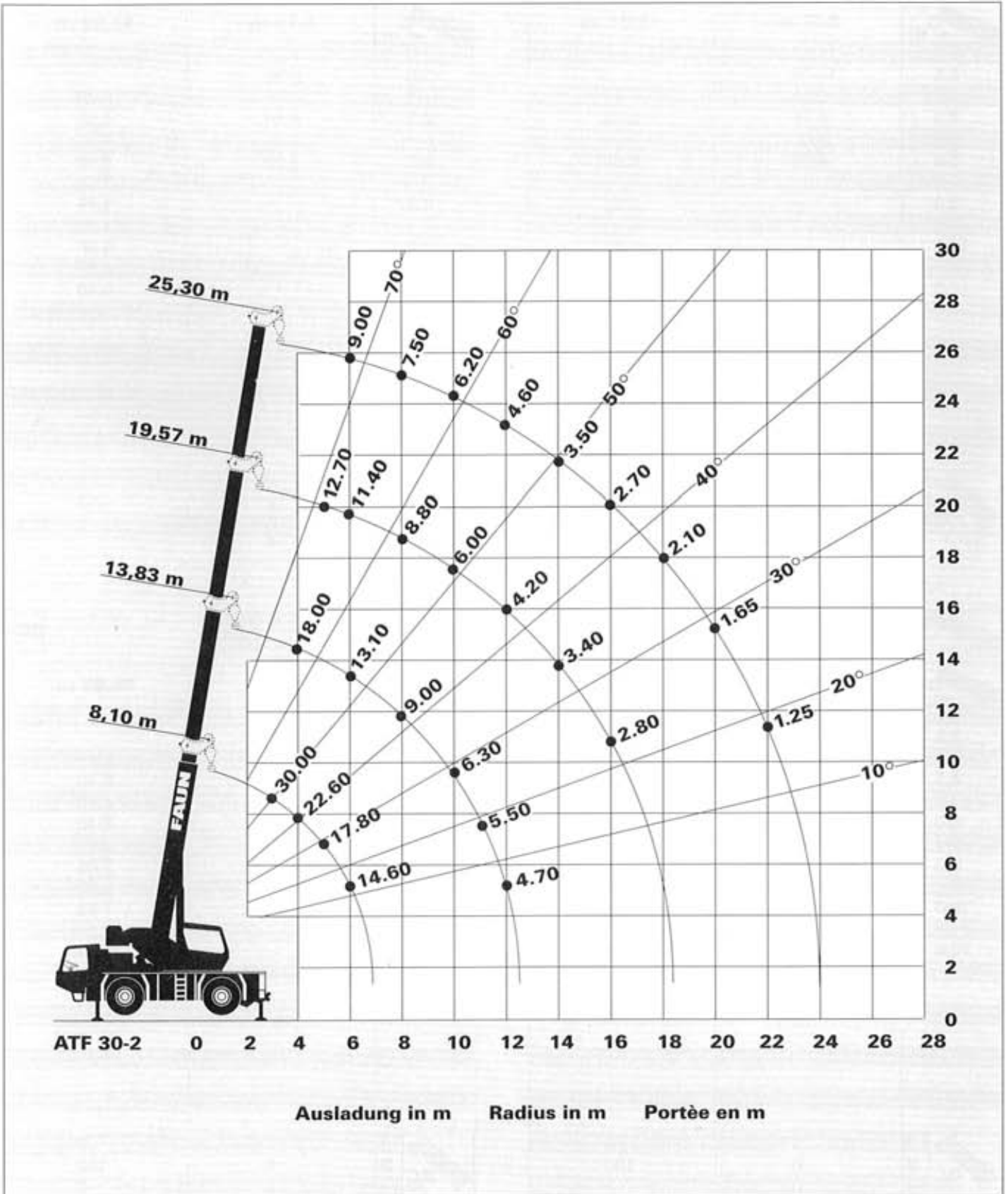







DIN











Tragfähigkeiten am Teleskopausleger  
 Lifting capacities on telescopic boom  
 Capacités de levage à la flèche telescopique

   <b>2,2t</b> <span style="float: right;"><b>DIN</b></span>			
 m	8.10 m	13.83 m	
3.0	11.50		
3.5	10.50		
4.0	9.55	9.60	
4.5	8.75	8.60	
5.0	8.00	8.05	
6.0	6.00	6.05	
7.0		4.80	
8.0		3.90	
9.0		3.15	
10.0		2.60	
11.0		2.15	
12.0		1.80	
<hr/>			
 %	I	0	0
	II	0	100
	III	0	0

   <b>2,2t</b> <span style="float: right;"><b>DIN</b></span>			
 m	8.10 m	13.83 m	
3.0	7.00		
3.5	5.95		
4.0	5.15	5.20	
4.5	4.50	4.55	
5.0	4.00	4.05	
6.0	3.00	3.00	
7.0		2.30	
8.0		1.75	
9.0		1.30	
10.0		0.90	
11.0		0.65	
12.0		0.40	
<hr/>			
 %	I	0	0
	II	0	100
	III	0	0

   <b>2,2t</b> <span style="float: right;"><b>85%</b></span>			
 m	8.10 m	13.83 m	
3.0	12.50		
3.5	11.40		
4.0	10.30	10.40	
4.5	9.50	9.30	
5.0	8.60	8.65	
6.0	6.60	6.65	
7.0		5.25	
8.0		4.35	
9.0		3.55	
10.0		3.00	
11.0		2.45	
12.0		2.10	
<hr/>			
 %	I	0	0
	II	0	100
	III	0	0

   <b>2,2t</b> <span style="float: right;"><b>85%</b></span>			
 m	8.10 m	13.83 m	
3.0	7.60		
3.5	6.55		
4.0	5.70	5.75	
4.5	5.00	5.10	
5.0	4.45	4.50	
6.0	3.35	3.40	
7.0		2.65	
8.0		2.05	
9.0		1.60	
10.0		1.15	
11.0		0.80	
12.0		0.55	
<hr/>			
 %	I	0	0
	II	0	100
	III	0	0

Hubhöhen  
Lifting heights  
Hauteurs de levage

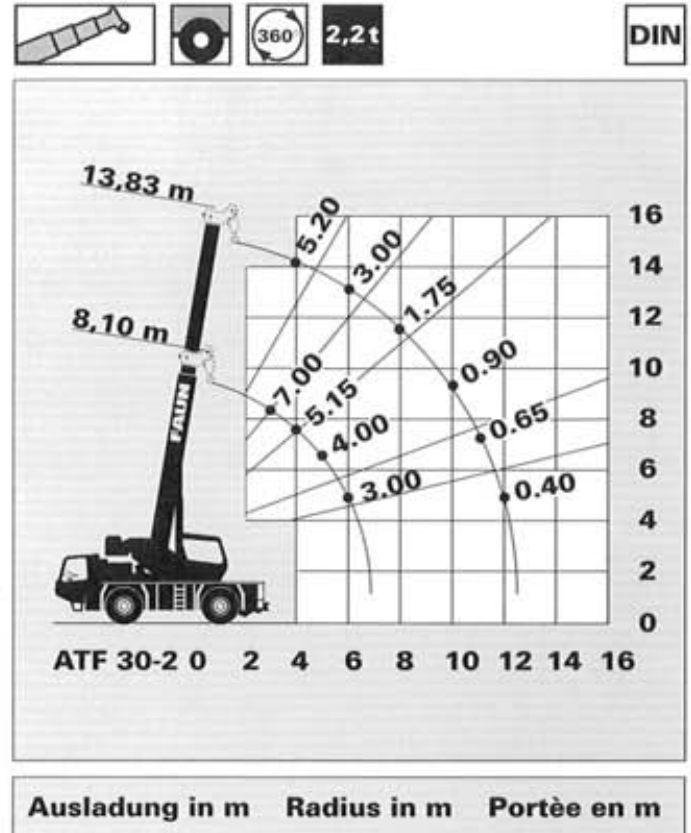
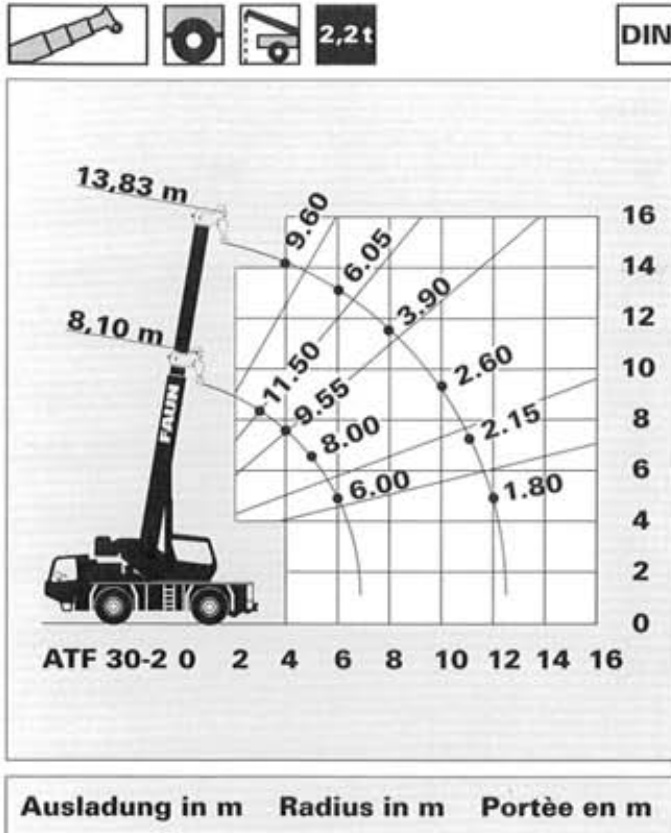

### Anmerkungen zu den Traglasttabellen

- Die angegebenen Traglasten überschreiten nicht 75% bzw. 85% der Kipplast.
- Die Traglasten entsprechen DIN 15019 Teil 2 und DIN 15018 Teil 3.
- Maximal zulässige Windgeschwindigkeit 15 m/sec.
- Die Traglasten sind in Tonnen angegeben.
- Das Gewicht des Lasthakens und der Schlingen usw. ist von den Traglasten abzuziehen.
- Der Radius ist der Abstand von Mitte Drehkranz bis Mitte freihängender, nicht schwingender Last.
- Die Traglasten für den Teleskopausleger gelten nur bei demontierter Spitze. Obige Angaben dienen nur zur Information. Die Bedienungsanleitungen müssen zu Rate gezogen werden, bevor die Maschine in Betrieb genommen wird. Alle hier gemachten Angaben beziehen sich auf die Standard-Ausführung. Jegliche Ausrüstungsveränderungen können die angegebenen Werte beeinflussen. **Änderungen vorbehalten.**

### Remarks relating to rating charts

- The lifting capacities shown do not exceed 75% or 85% of the tipping load.
- The lifting capacities shown comply with DIN 15019 (Part 2) and DIN 15018 (Part 3).
- Maximum allowable wind speed by crane operation is 15 m/sec.
- The lifting capacities shown are in metric tons.
- The weight of load handling devices such as hook blocks, slings, etc., shall be considered part of the load.
- Operating radius is the horizontal distance from the vertical axis of rotation of the upper superstructure to the centre of the load handling device with the load applied.
- The telescopic boom capacities shown apply to a machine without any boom extensions being on the machine (either stored or mounted). The above remarks are for basic information only and the operator's manual must be consulted before operating this machine. All data and performances refer to a standard machine. The additional of optional or other equipment may affect the performance of the machine. **The information contained in this bulletin is subject to change without prior notice.**

### Remarques relatives aux tableaux des charges

- Les forces de levage indiquées ne dépassent pas 75% ou 85% de la charge de basculement.
- Les forces de levage conformes à la norme DIN 15019.2 e DIN 15018.3.
- Le grue peut travailler jusqu'à une vitesse du vent de 15 m/s.
- Les forces de levage sont données en tonnes.
- Le poids du crochet-moufle et de tous les accessoires d'elingage font partie de la charge et sont à déduire des charges indiquées.
- Les portées sont calculées à partir de l'axe de rotation.
- Les forces de levage indiquées pour la flèche télescopique s'entendent fléchette déposée. Les données ci-dessus servent à titre d'information. Avant mise en marche de la grue il est conseillé d'étudier les manuels d'opération. Toutes données ci-dessus se réfèrent à la machine de base. Tout changement de l'équipement de la grue peut influencer les valeurs indiquées. **Sous réserve de modification.**

Tragfähigkeiten an der Spitze\*  
 Lifting capacities on boom extension\*  
 Capacités de levage à la rallonge de flèche\*



DIN

	8.00 m		
	0°	15°	30°
6.0			
7.0			
8.0	4.00		
9.0	3.75		
10.0	3.50	2.60	
11.0	3.25	2.50	
12.0	3.05	2.45	2.10
14.0	2.65	2.25	1.95
16.0	2.30	2.00	1.80
18.0	2.00	1.80	1.65
20.0	1.75	1.60	1.55
22.0	1.40	1.45	1.40
24.0	1.10	1.15	1.20
26.0	0.85	0.90	0.90
28.0	0.65	0.65	0.65
30.0	0.45	0.45	0.45

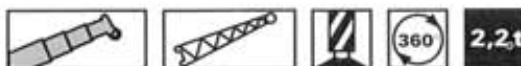

85%

	8.00 m		
	0°	15°	30°
6.0			
7.0			
8.0	4.40		
9.0	4.15		
10.0	3.85	2.85	
11.0	3.60	2.75	
12.0	3.35	2.65	2.30
14.0	2.90	2.50	2.10
16.0	2.50	2.20	2.00
18.0	2.20	2.00	1.85
20.0	1.95	1.75	1.70
22.0	1.55	1.60	1.55
24.0	1.30	1.45	1.40
26.0	1.05	1.10	1.10
28.0	0.80	0.80	0.80
30.0	0.60	0.60	0.60



Hubhöhen  
Lifting heights  
Hauteurs de levage



DIN

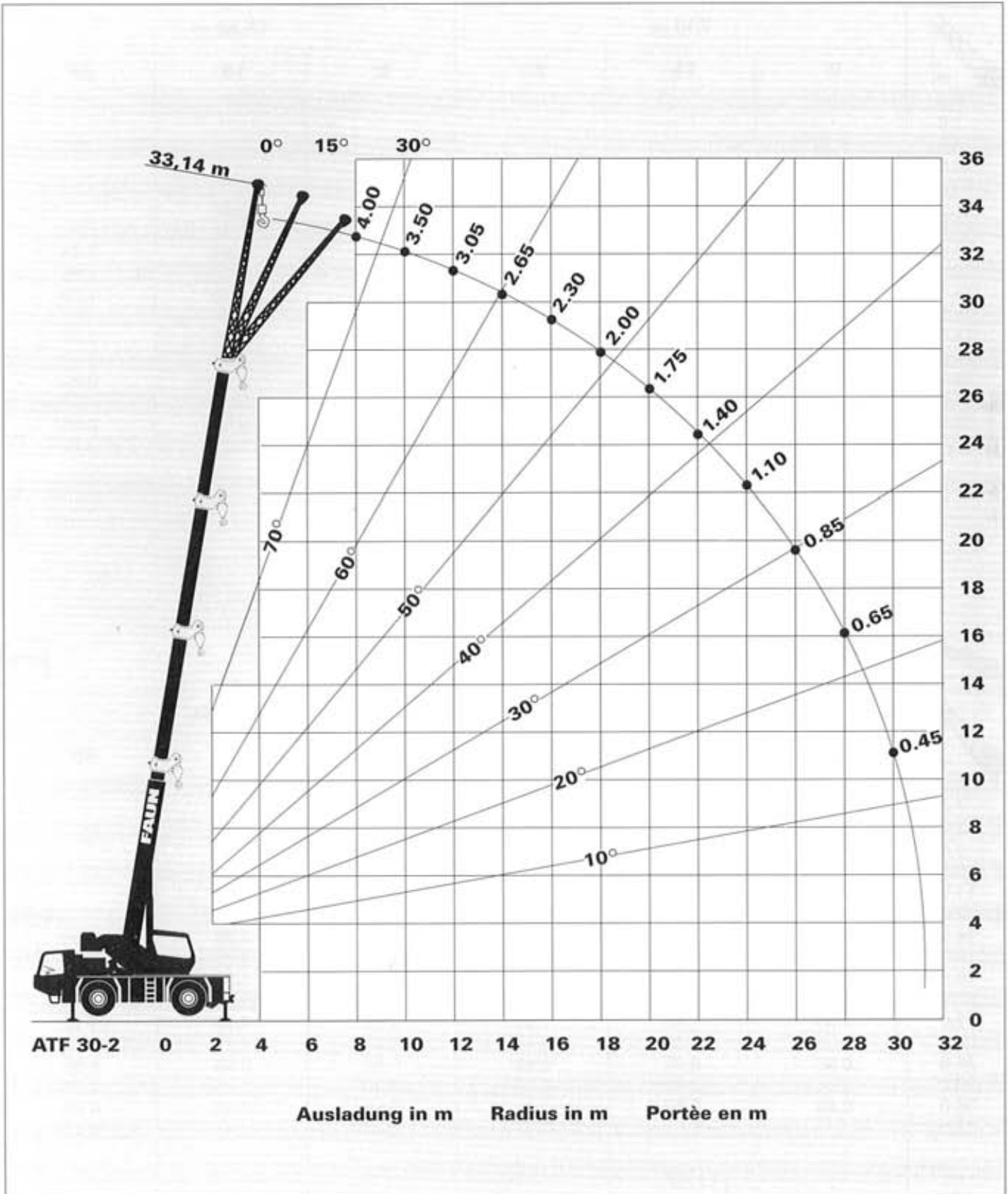

Tragfähigkeiten an der Spitze\*  
 Lifting capacities on boom extension\*  
 Capacités de levage à la rallonge de flèche\*

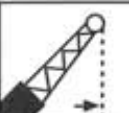

DIN

	7.10 m			12.20 m		
	0°	15°	30°	0°	15°	30°
6.0						
7.0						
8.0	5.50					
9.0	5.00			2.95		
10.0	4.50	3.20		2.85		
11.0	4.10	2.95		2.70	2.05	
12.0	3.75	2.70	2.40	2.55	1.95	
14.0	3.15	2.40	2.15	2.15	1.80	1.45
16.0	2.70	2.05	1.90	1.80	1.55	1.35
18.0	2.10	1.85	1.70	1.55	1.35	1.20
20.0	1.65	1.65	1.55	1.35	1.20	1.10
22.0	1.30	1.30	1.40	1.20	1.05	1.00
24.0	1.00	1.05	1.10	1.05	0.95	0.90
26.0	0.75	0.80	0.85	0.85	0.85	0.80
28.0	0.55	0.60	0.60	0.65	0.70	0.75
30.0	0.35	0.40		0.45	0.50	0.55
32.0				0.30	0.35	0.35

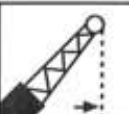

85%

	7.10 m			12.20 m		
	0°	15°	30°	0°	15°	30°
6.0						
7.0						
8.0	6.00					
9.0	5.50			3.25		
10.0	4.95	3.50		3.10		
11.0	4.55	3.25		2.95	2.25	
12.0	4.15	3.00	2.65	2.80	2.15	
14.0	3.55	2.60	2.35	2.35	1.95	1.60
16.0	3.05	2.30	2.10	2.00	1.70	1.50
18.0	2.40	2.05	1.85	1.75	1.50	1.35
20.0	1.90	1.80	1.70	1.50	1.35	1.25
22.0	1.50	1.45	1.55	1.35	1.20	1.15
24.0	1.15	1.20	1.25	1.20	1.10	1.05
26.0	0.85	0.90	0.95	0.95	0.95	0.90
28.0	0.65	0.70	0.70	0.80	0.85	0.90
30.0	0.45	0.50		0.55	0.60	0.65
32.0				0.40	0.45	0.45

Hubhöhen  
Lifting heights  
Hauteurs de levage



DIN

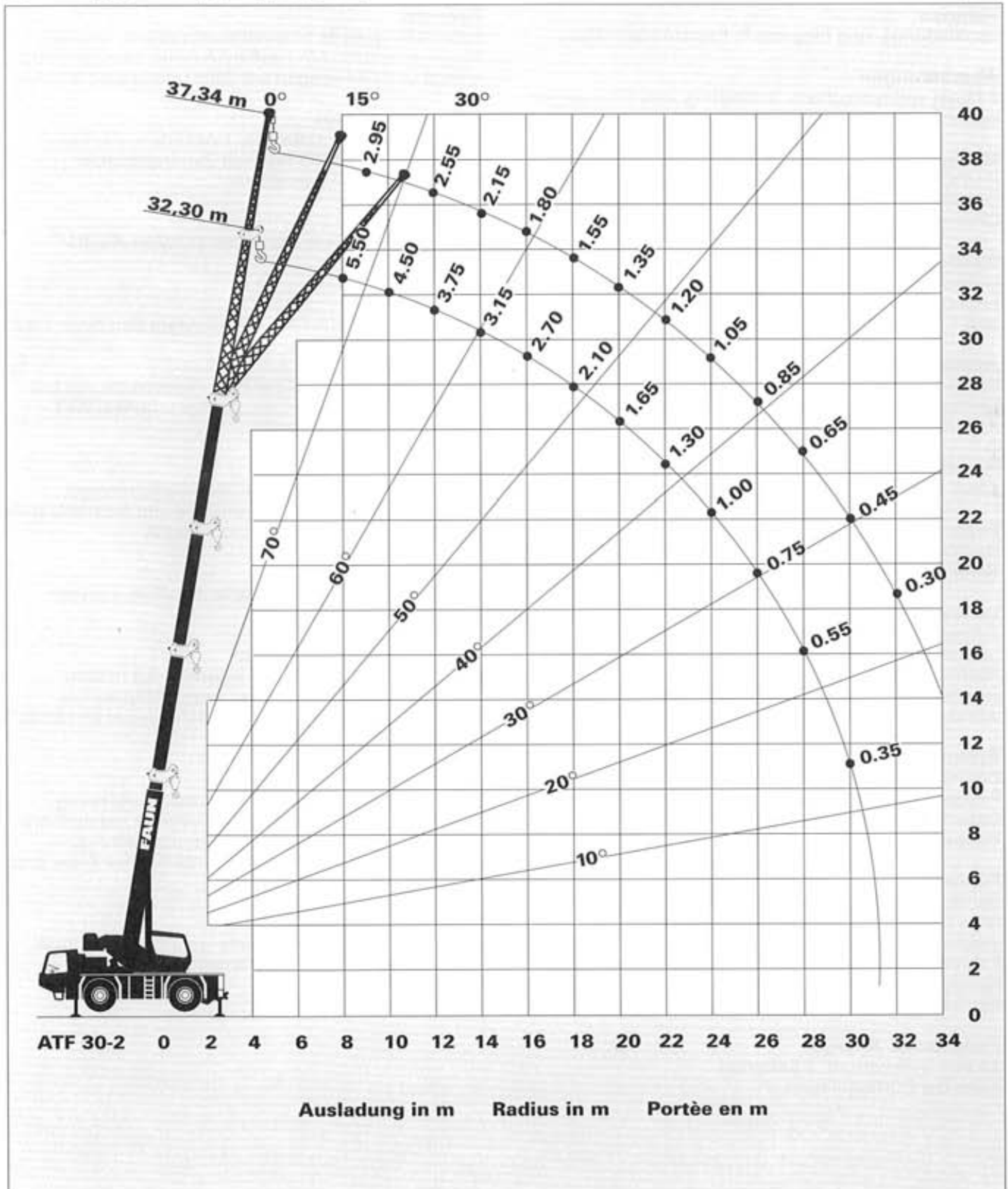



### Rahmen

Verwindungs- und biegesteife Kastenkonstruktion.

### Abstützungen

4-Punkt vollhydraulisch. Betätigung vom Oberwagen sowie links und rechts am Fahrgestell.

### Motor

(EURO 1) 6 Zylinder Mercedes Benz wassergekühlt OM 401 LA, 200 kW (272 PS bei 2100 U/min.)  
Drehmoment: 1090 Nm bei 1200 U/min.

### Getriebe

Lastschaltgetriebe mit Drehmomentwandler und Lock-up-Kupplung (ab 1. Gang) mit 6 Vorwärts- und 1 Rückwärtsgang.

### Achsen

Vorne: Planetenachse mit Differentialsperre, lenkbar.  
Hinten: Planetenachse mit Differentialsperre, lenkbar.  
Antrieb: 4 x 2 / 4 x 4.

### Bereifung

4fach 14.00 R 25 / 16.00 R 25\*.

### Federung

Hydro-pneumatisch, hydraulisch blockierbar mit Niveauregulierung.

### Lenkung

2-Kreis-Hydro-Halblocklenkung. Mechanische Lenkung der Vorderachse, hydraulisch unterstützt, mit Notlenkpumpe. Lenkung der Hinterachse hydraulisch zuschaltbar. Hydrostatische Lenkung beider Achsen aus der Krankabine.

### Bremsen

Betriebsbremse: Zweikreis-Druckluft-Bremsanlage.  
Feststellbremse: Federspeicher an beiden Achsen.  
Dauerbremse: Konstantdrossel-Anlage und Auspuffklappenbremse.

### Fahrerhaus

Seitlich (links) auf dem Fahrgestell. Einmann Fahrerhaus in Stahl-GFK-Verbundkonstruktion, Sicherheitsverglasung, gefederter und hydraulisch gedämpfter Fahrersitz und motorabhängige Warmwasserheizung. Kontroll- und Bedienungselemente für den Fahrbetrieb. Zweimann Fahrerhaus\*.

### Elektrische Anlage

24 Volt Gleichstrom, 2 Batterien.  
Nach der EG-Regulation.



### Rahmen

Verwindungssteife Schweißkonstruktion. 1reihige Kugeldrehverbindung außenverzahnt zwischen Fahrgestell und Oberwagen um 360° unbegrenzt drehbar.

### Hydrauliksystem

Dreikreis-Hydraulik-Anlage. 1 Axialdoppelkolben-Verstellpumpe und 1 dreifach-Zahnradpumpe angetrieben vom Fahrmotor.

### Steuerung

2 selbstzentrierende Steuerhebel, hydraulische Vorsteuerung.

### Wippwerk

1 Differentialzylinder mit angebautem Senkbremsventil.

### Drehwerk

Hydromotor, zweistufiges Planetengetriebe mit fußbetätigter Betriebsbremse. Drehgeschwindigkeit stufenlos von 0-2,4 U/min.

### Hubwerk

Axialkolben-Konstantmotor, Hubwerkstrommel mit eingebautem Planetengetriebe und federbelasteter Haltebremse mit integriertem Freilauf.

### Teleskopausleger

1 Grundkörper, 3 Teleskopteile. Alle Teleskopteile hydraulisch verschiebbar.

### Auslegerverlängerungen\*

Gitterkonstruktion, seitlich klappbar, 8.0 m lang, unter 0°/15°/30° montierbar, Doppelklappspitze, seitlich klappbar, 7.1 m - 12.2 m lang, unter 0°/15°/30° montierbar.

### Kranfahrerkabine

Ganzstahlausführung mit Sicherheitsverglasung, gefederter und hydraulisch gedämpfter, verstellbarer Sitz und motorunabhängige Warmluftheizung. Kontroll- und Bedienungselemente für den Kran- und Fahrbetrieb.

### Sicherheitseinrichtungen

Sicherheitsventile gegen Rohr- und Schlauchbruch, Windenendschalter, Lastmomentbegrenzung und Hubendschalter.



### Frame

Torsion and bend resistant box type steel construction.

### Outriggers

4 point hydraulic outriggers controlled from upper cab and from both sides of carrier.

### Engine

(EURO 1) 6 cylinder Mercedes Benz water-cooled engine OM 401 LA, 200 kW (272 HP) at 2100 RPM.

### Transmission

Powershift transmission with torque converter lock-up (from 1st gear) with 6 forward gears and 1 reverse gear.

### Axles

Front: planetary axle with differential lock, steerable.  
Rear: planetary axle with differential lock, steerable.  
Drive: 4 x 2/4 x 4.

### Wheels

14.00 R 25/16.00 R 25\*

### Suspension

Hydro-pneumatic, hydraulically lockable with levelling adjustment.

### Steering

Dual circuit semi-block. Front axle mechanically steered with hydraulic assistance and emergency pump. Rear axle hydraulically steered. Both axles hydro-statically steered from upper cab.

### Brakes

Service brake: dual circuit air brakes.  
Parking brake: spring load acting on all wheels.  
Engine brake: constant throttle system and engine exhaust brake.

### Driver's Cab

Left hand mounted Panoramic design. One man composite construction cab with safety glass and hydraulically cushioned adjustable seat. Controls and instrumentation for driving. Heater engine dependent. Two man cab.\*

### Electrical System

24 volt DC system with 2 batteries. According to EEC regulations.



### Frame

All welded torsion resistant steel structure with single row ball-bearing slewing ring with external gears for 360° continuous rotation.

### Hydraulic System

Engine driven 3 circuit hydraulic system with one variable displacement three section axial piston pump and one fixed displacement pump.

### Controls

2 joy-stick type control levers for simultaneous crane motions, infinitely controlled.

### Boom Hoist

One double acting hydraulic cylinder with integral safety check valve.

### Slewing Gear

Hydraulic motor with planetary reduction with foot controlled service brake and automatic holding brake. Slewing speed 0-2.4 U/min.

### Main Winch

Axial piston fixed displacement motor with planetary reduction and spring loaded multiple disc holding brake.

### Telescopic boom

1 boom base and 3 telescoping sections. All sections hydraulically extendable under load.

### Boom Extensions\*

Lattice type boom extension 8.0 m Offsets 0°/15°/30°.  
Lattice type double folding extension 7.1 m - 12.2 m Offsets 0°/15°/30°.

### Crane Cab

Left hand mounted Panoramic design. Spacious all-steel structure with special safety glass, hydraulically cushioned adjustable seat and independent hot-air heater. Controls and instrumentation for crane operation and travelling.

### Safety Devices

Safety valves against hose and pipe rupture and main winch limit switch. Electronic load moment device and anti-two block device.





**Châssis** Construction mécano-soudée, en forme de caisson, résistante aux flexions et aux torsions.

**Calage** 4 poutres extensibles hydrauliquement à partir de la cabine du grutier et latéralement à gauche et à droite du châssis.

**Moteur** (EURO 1) Mercedes-Benz diesel OM 401 LA, 200 kW (272 CV à 2100 tr/min) refroidi par eau. Couple-moteur: 1090 Nm à 1200 tr/min. Puissance selon DIN 6270 B

**Boîte de vitesses** Boîte powershift avec convertisseur de couple et embrayage lock-up (à partir de 1ère vitesse) avec 6 vitesses AV et 1 AR

**Essieux** Essieu AV: essieu à planétaires avec blocage différentiel, directeur.  
Essieu AR: essieu à planétaires avec blocage différentiel, directeur.

**Entraînement** 4x2/4x4.

**Pneumatiques** 4 pneus de 14.00 R 25/16.00 R 25.\*

**Suspension** Hydro-pneumatique, réglage d'inclinaison à suspension bloquée.

**Direction** Direction hydraulique semi-bloc à 2 circuits. Direction mécanique de l'essieu avant, avec pompe hydr. de secours. Conjonction de direction de l'essieu arrière hydrauliquement. Direction hydrostatique des 2 essieux à partir de la cabine tourelle.

**Freins** Frein de service: système de frein à air comprimé à double circuit.  
Frein de parcage:  
Frein à accumulateur à ressorts sur l'essieu AV et AR.  
Frein permanent:  
Ralentisseur et clapet d'échappement à commande pneumatique.

**Cabine de Conducteur** Cabine monoplace, construction en matière combinée, avec vitrage en verre de sécurité, siège du conducteur à ressort et amorti hydrauliquement. Chauffage à eau chaude dépendant du moteur. Tableau de bord avec instruments de contrôle et conduite. Cabine bi-place.\*

**Système électrique** 24 V courant continu, 2 batteries, conforme aux normes CEE.



**Plate forme** Construction mécano-soudée, résistant à la torsion. Couronne d'orientation avec denture extérieure, permettant une rotation illimitée à 360°.

**Système hydraulique** Diesel-hydraulique, installation hydraulique à 3 circuits, 1 pompe à piston axial (réglage hydraulique) 1 pompe triple à engrenages entraînée par le moteur porteur.

**Commandes** 2 leviers à commande manuelle universelle et à autocentrage, assistés hydrauliquement.

**Mécanisme de relevage** Vérin différentiel muni de clapet de sécurité.

**Mécanisme de rotation** Moteur hydraulique avec entraînement planétaire biétagé. Frein de service actionné par l'intermédiaire d'une pédale, vitesse de rotation 0 à 2.4 tr/min.

**Mécanisme de levage** Moteur hydraulique, tambour de levage avec boîte planétaire incorporée, frein d'arrêt à disques multiples à ressort, libéré lors du levage.

**Flèche télescopique** 1 élément de base et 3 éléments télescopiques, tous hydrauliquement télescopables.

**Rallonge de flèche\*** Construction en treillis, longueur 8,0 m, rabattable latéralement. Fléchette double. Construction en treillis, longueur 7,10 m/12,10 m, rabattable latéralement inclinable à 0°/15°/30°.

**Cabine de conduite** En acier avec vitrage de sécurité, siège suspendu sur ressorts, amorti hydrauliquement et réglable. Chauffage à air chaud indépendant du moteur. Tableau de bord avec instruments de contrôle et de conduite.

**Dispositifs de sécurité** Clapets anti-retour contre l'éventuelle rupture des conduites ou flexibles, interrupteur de fin de course du treuil pour câble de levage sur le tambour, limiteur de couple de charge, interrupteur de fin de course de levage.







016/04/V 96/05/d,e,f/Bi

### HOW TO CALL GERMANY:

(A)	from/to		0 60
(B)	(CH) (I)		00 49
(DK)	(S)		0 09 49
(E)			07 49
(F)			19 49
(GB)			0 10 49
(N)			0 95 49
(NL)			00 49

### NIGHT & DAY

		(0) 91 23 95 50
		(0) 17 18 11 43 24
		(0) 91 23 18 51 55
		(0) 91 23 18 52 19

### SERVICE

	622 990
---	---------

**24<sup>h</sup>**  
**STUNDEN**